

*Thank You for Selecting*  
The Powerful **QUIET BLOW® BLOWER**

## Operator Owner's Manual

*For Models:*

***BL53PNCE***

### *Specifications*

---

**BL53PNCE**

---

ENGINE: HP	5.0 HP (3.73 kW)
ENGINE: TYPE	B & S
ENGINE: FUEL CAP.	3.0 qt. ( 2.85 L)
ENGINE: OIL CAP.	0.66 qt. (0.62 L)
WEIGHT: UNIT	63 # ( 28.57 Kg)
WEIGHT: SHIPPING	73 # (33.11 Kg)
ENGINE WEIGHT:	30 # (13.6 Kg)

*UNIT SIZE:*      OVERALL LENGTH: 38.25" ( 0.97m)    OVERALL WIDTH 20.0" ( 0.51m)    OVERALL HEIGHT 40" ( 1.02m)

# IN THE INTEREST OF SAFETY



BEFORE STARTING ENGINE, READ AND UNDERSTAND THE "ENTIRE OPERATOR'S MANUAL & ENGINE MANUAL."



THIS SYMBOL MEANS WARNING OR CAUTION. DEATH, PERSONAL INJURY AND/OR PROPERTY DAMAGE MAY OCCUR UNLESS INSTRUCTIONS ARE FOLLOWED CAREFULLY.



**WARNING:** The Engine Exhaust from this product contains chemicals known to the State of California to cause cancer, birth defects or other reproductive harm.

## WARNING: DO NOT

1. **DO NOT** run engine in an enclosed area. Exhaust gases contain carbon monoxide, an odorless and deadly poison.
2. **DO NOT** place hands or feet near moving or rotating parts.
3. **DO NOT** store, spill or use gasoline near an open flame, or devices such as a stove, furnace, or water heater which use a pilot light or devices which can create a spark.
4. **DO NOT** refuel indoors where area is not well ventilated. Outdoor refueling is recommended.
5. **DO NOT** fill fuel tank while engine is running. Allow engine to cool for 2 minutes before refueling. Store fuel in approved safety containers.
6. **DO NOT** remove fuel tank cap while engine is running.
7. **DO NOT** operate engine when smell of gasoline is present or other explosive conditions exist.
8. **DO NOT** operate engine if gasoline is spilled. Move machine away from the spill and avoid creating any ignition until the gasoline has evaporated.
9. **DO NOT** transport unit with fuel in tank.
10. **DO NOT** smoke when filling fuel tank.
11. **DO NOT** choke carburetor to stop engine. Whenever possible, gradually reduce engine speed before stopping.
12. **DO NOT** run engine at excessive speeds. This may result in injury & /or damage to unit.

13. **DO NOT** tamper with governor springs, governor links or other parts which may change the governed engine speed.
14. **DO NOT** tamper with the engine speed selected by the engine manufacturer.
15. **DO NOT** check for spark with spark plug or spark plug wire removed. Use an approved tester.
16. **DO NOT** crank engine with spark plug removed. If engine is flooded, place throttle in "FAST" position and crank until engine starts.
17. **DO NOT** strike flywheel with a hard object or metal tool as this may cause flywheel to shatter in operation. Use proper tools to service engine.
18. **DO NOT** operate engine without a muffler. Inspect periodically and replace, if necessary. If engine is equipped with muffler deflector, inspect periodically and replace, if necessary, with correct deflector.
19. **DO NOT** operate engine with an accumulation of grass, leaves, dirt or other combustible material in the muffler area.
20. **DO NOT** use this engine on any forest covered, brush covered, or grass covered unimproved land unless a spark arrester is installed on the muffler. The arrester must be maintained in effective working order by the operator. In the State of California the above is required by law (Section 4442 of the California Public Resources Code). Other states may have similar laws. Federal laws apply on federal lands.

21. **DO NOT** touch hot muffler, cylinder, or fins because contact may cause burns.
22. **DO NOT** run engine without air cleaner or air cleaner cover.
23. **DO NOT** operate during excessive vibration!
24. **DO NOT** leave machine unattended while in operation.
25. **DO NOT** park machine on a steep grade or slope.

## WARNING: DO



1. **ALWAYS DO** remove the wire from the spark plug when servicing the engine or equipment TO PREVENT ACCIDENTAL STARTING.
2. **DO** keep cylinder fins and governor parts free of grass and other debris which can affect engine speed.
3. **DO** pull starter cord slowly until resistance is felt. Then pull cord rapidly to avoid kickback and prevent hand or arm injury.
4. **DO** examine muffler periodically to be sure it is functioning effectively. A worn or leaking muffler should be repaired or replaced as necessary.
5. **DO** use fresh gasoline. Stale fuel can gum carburetor and cause leakage.
6. **DO** check fuel lines and fittings frequently for cracks or leaks. Replace if necessary.
7. **Follow** engine manufacturer operating and maintenance instructions.
8. **Inspect** machine and work area before starting unit.

### 6 TABLE OF CONTENTS

SAFETY INSTRUCTIONS	2
GENERAL SAFETY	3
ASSEMBLY	3
LABELS	4
PARTS BAG & CONTROLS	4
OPERATION	5
PARTS DRAWING & LIST	6 - 7
MAINTENANCE	8
TROUBLESHOOTING	8
WARRANTY PROCEDURE	8

7

### SOUND

ε L<sub>WA</sub>  
**84**

SOUND TESTS  
Sound tests conducted were in accordance with 79/113/EEC and were performed on 06/13/95 under the conditions listed:

GENERAL CONDI- Sunny  
TION:

TEMPERATURE: 69° F (20.5° C)

WIND SPEED: 12 MPH (19.3 kmh)

WIND DIRECTION: South

HUMIDITY: 55%

3 L<sub>pA</sub>  
**95**

OPERATOR BAROMETRIC PRESSURE: 30.13" Hg (765 mm Hg)

8

### VIBRATION

VIBRATION LEVELS 2.1 g

Vibration levels at the operators handles were measured in the vertical, lateral, and longitudinal directions using calibrated vibration test equipment. Tests were performed on 06/13/95 under the conditions listed:

GENERAL CONDI- Sunny  
TION:

TEMPERATURE: 69° F (20.5° C)

WIND SPEED: 12 MPH (19.3 kmh)

WIND DIRECTION: South

HUMIDITY: 55%

BAROMETRIC PRESSURE: 30.13" Hg (765 mm Hg)

# GENERAL SAFETY

*For your safety and the safety of others, these directions should be followed:*



Do not operate this machine without first reading owner's manual and engine manufacturer's manual.



Use of Ear Protection is recommended while operating this machine.



Use of Eye and breathing protection is recommended when using this machine, especially in dry and dusty conditions.

- DO NOT place hands or feet inside air intake opening, near exhaust outlet or near any moving parts.
- DO NOT start engine without deflector attached to exhaust outlet.

- DO NOT direct exhaust outlet toward any bystanders.
- DO NOT operate this equipment without first inspecting work area.
- DO NOT operate this equipment during excessive vibration.
- DO NOT start engine without housing front plate attached.
- DO NOT operate this machine on slopes greater than 20%.
- DO NOT blow any hot or burning debris, or any toxic or explosive material.
- DO NOT allow children to operate this equipment.

# ASSEMBLY



Read all safety and operating instructions before assembling or starting this unit.



**PUT OIL IN ENGINE BEFORE STARTING**

Your Billy Goat is shipped from the factory in one carton, completely assembled except for the upper handle and plate deflector.

1. Install upper handles (Item 31), to preassembled lower handle (item 29), using two screws (Item 30), and two nut locks, (Item 2). Securely tighten all fasteners.
2. Locate deflector (item 39). See page 5.
3. Connect spark plug wire.

**NOTE:** Front wheel bracket (Item 17), can be inverted to provide a 0.5" (12.7mm) height adjustment.

# PACKING CHECKLIST

These items should be included in your carton. If any of these parts are missing, contact your dealer.

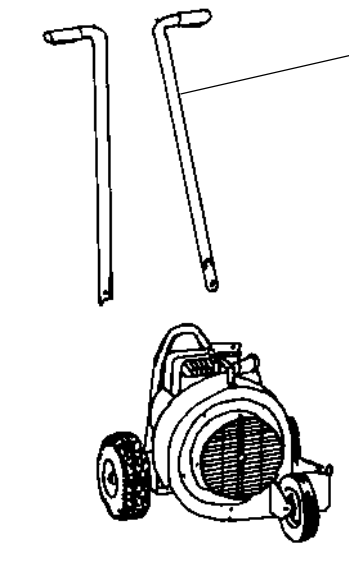

## Boxing Checklist

Check <input type="checkbox"/>	Handle Upper Assembly (2) 400434
Check <input type="checkbox"/>	Deflector - Side 400417
<i>Per Model</i>	
Check <input type="checkbox"/>	Literature Assy 400994
<i>Per Model</i>	
Check <input type="checkbox"/>	Briggs & Stratton 5 HP P/N 270367 MS9249 Multi-Language

Literature Assy

Engine Manual

12

## LITERATURE ASSY P/N 400994

Literature Checklist	
Owner's Manual	<input type="checkbox"/> Check Owner's Manual 400992
Literature Sales Turf Products	<input type="checkbox"/> Check Literature Sales Turf Products 900511
Warranty Card	<input type="checkbox"/> Check Warranty Card 400972
EU Declaration of Conformity	<input type="checkbox"/> Check EU Declaration of Conformity 400995

13

## CONTROLS

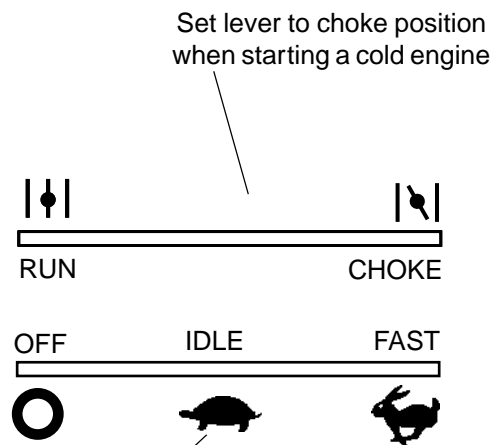

Set lever to desired engine speed.  
 Move lever completely to the left to stop engine.

14

## INSTRUCTION LABELS

These labels should be included on your Blower. If any of these labels are damaged, replace them before putting this equipment into operation. Item and part numbers are given to help in ordering replacement labels.



Label Do Not Fill While Engine Is Hot  
 Item 11 Part No. 400268



Label Read Owner's Manual  
 Item No. 59 Part No. 890301



Label Danger Flying Material  
 Item No. 44 Part No. 810736

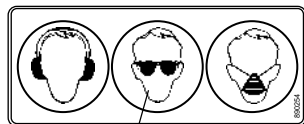

Label Ear Eye Breathing  
 Item No. 63 Part No. 890254

Label Danger Keep Hands and Feet Away  
 Item 41 Part No. 400424

15

## ENGINE LABELS

Briggs &amp; Stratton

Read Owner's Manual Before Operating.

Lire le manuel d'utilisation avant la mise en route.

Vor Inbetriebnahme Bedienungs- und Wartungsanleitung lesen.

Favor leer las instrucciones de operación antes de operar el motor.

Consultare il Manuale 'Usò e Manutenzione prima dell' utilizzo.

Läs Skötselinstruktioner Innan Start.



**INTENDED USE:** This machine is designed for cleaning outdoor surfaces, where the debris can be effectively blown into a consolidated area for convenient pickup and removal.

Do not operate if excessive vibration occurs. If excessive vibration occurs, shut engine off immediately and check for damaged or worn impeller, loose impeller bolt, loose impeller key, loose engine or lodged foreign objects.

Note: See parts list for proper impeller bolt torque specifications. (See trouble shooting section on page 8).



Like all mechanical tools, reasonable care must be used when operating machine.

**Inspect machine work area and machine before operating. Make sure that all operators of this equipment are trained in general machine use and safety.**



**PUT OIL IN ENGINE BEFORE STARTING**

16.1

### STARTING



**ENGINE:** See engine manufacturer's instructions for type and amount of oil and gasoline used.

Engine must be level when checking and filling oil and gasoline.

**ENGINE SPEED:** Controlled by throttle lever on the engine. Under normal conditions, operate at minimum throttle to accomplish your current cleaning task.

**CHOKE:** Operated with choke lever on face of engine.

**THROTTLE:** Move throttle control on face of engine, to fast position. Pull starting rope to start engine.

**IF YOUR UNIT FAILS TO START:**

See Troubleshooting on page 8.

16.2

### BLOWING OPERATION

Deflector (item 39) can be installed aiming upward for improved leaf blowing capabilities or downward for hard surface blowing.



Fig. 1

### EXHAUST AIR DEFLECTOR ADJUSTMENT:

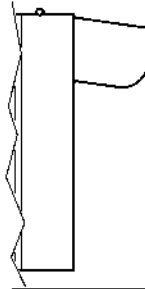

Fig. 2

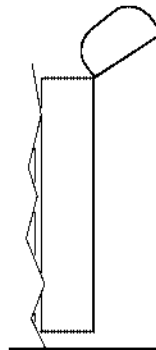

Fig. 3

16.4

### HANDLING & TRANSPORTING:

Using two people to lift machine is recommended. Lift holding the handle and handle lift. Secure in place during transport or when unattended.

16.5

### STORAGE

**⚠** Never store engine indoors or in enclosed poorly ventilated areas with fuel in tank, where fuel fumes may reach an open flame, spark or pilot light, as on a furnace, water heater, clothes dryer or other gas appliance.

**If engine is to be unused for 30 days or more, prepare as follows:**

Remove all gasoline from carburetor and fuel tank to prevent gum deposits from forming on these parts and causing possible malfunction of engine. Drain fuel outdoors, into an approved container, away from open flame. Be sure engine is cool. Do not smoke. Run engine until fuel tank is empty and engine runs out of gasoline.

**NOTE:** Fuel stabilizer (such as Sta-Bil) is an acceptable alternative in minimizing the formation of fuel gum deposits during storage. Add stabilizer to gasoline in fuel tank or storage container. Always follow mix ratio found on stabilizer container. Run engine at least 10 min. after adding stabilizer to allow it to reach the carburetor.

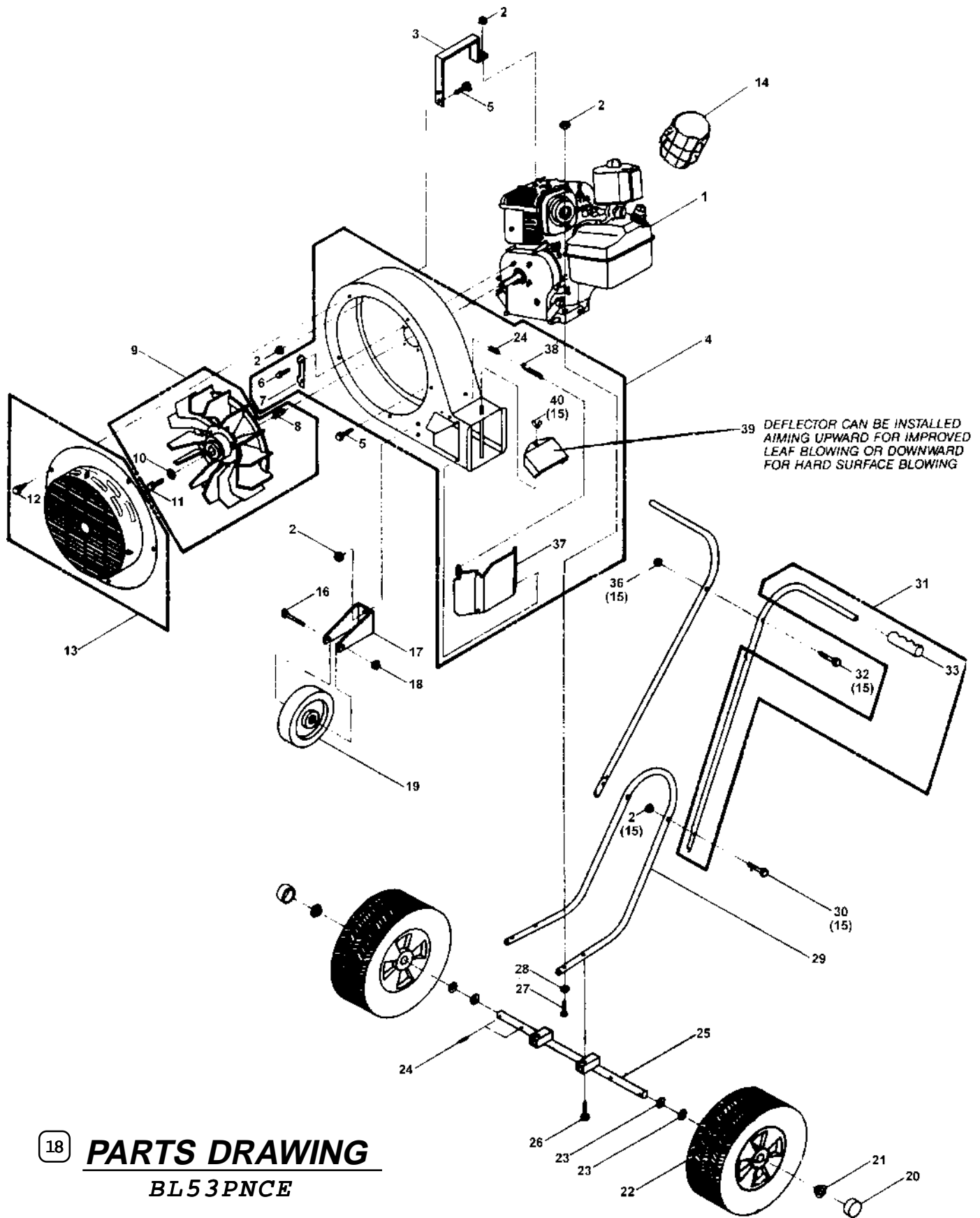

**18 PARTS DRAWING**  
**BL53PNCE**



Item No.	19 PARTS LIST	Description	BL53PNCE	Qty.	Part No.	Qty.
			Part No.			
1		Engine - 5.0 HP Briggs & Stratton	400220	1		
2		Nut Lock 5/16 - 18	*8160002	10		
3		Handle Lift	400204	1		
4		Housing Assembly (incl. items (qty): 6(4), 7(2), 24(2), 37(1), 38(1), 39(1), 40(1), 12(2))	400435	1		
5		Screw Cap 5/16 - 18 x 3/4	*8041026	3		
6		Screw Cap 5/16 - 24 x 3/4 GR5	*8042026	4		
7		Lock Clip	400218	2		
8		Key Square 1/4 x 2.25	9201123	1		
9		Impeller Assembly (incl. items (qty): 8(1), 10(1), 11(1))	400421	1		
10		Washer Lock 3/8 Twisted Tooth	400502	1		
11		Screw Cap 3/8 - 24 x 1 GR8 [torque 50 ft-lbs (67.8 N-m)]	900154	1		
12		Screw Sheet Metal 1/4 x 3/4 long Hex washer face	*8122082	5		
13		Grill Assembly (includes studs (2) nut (4) and item 12(5))	400433B	1		
14		Guard Muffler Assembly	400990	1		
15						
16		Screw Cap 1/2 - 13 x 2 1/2	*8041100	1		
17		Bracket Front Wheel	400209	1		
18		Nut Lock 1/2 - 13	*8160005	1		
19		Wheel Front	400249	1		
20		Hub Cap	900486	2		
21		Washer Hub Cap	850237	2		
22		Wheel Rear Pneumatic	400295	2		
23		Washer Flat 3/4 SAE	*8172015	6		
24		Pin Cotter 1/8 x 1	*8197031	5		
25		Axle WA	400202	1		
26		Screw Cap 5/16 - 18 x 2 3/4	*8041035	2		
27		Screw Cap 5/16 - 18 x 2 1/4	*8041033	2		
28		Washer Flat 5/16 SAE	*8172008	2		
29		Handle Lower	400124	1		
30		Screw Cap 5/16 - 18 x 1 1/2	*8041030	2		
31		Handle Upper Assembly (Includes item (qty): 33(1))	400434	2		
32		Screw Cap 1/4 - 20 x 2	*8041010	1		
33		Handle Grip	400234	2		
34						
35						
36		Nut Lock 1/4 - 20	*8160001	1		
37		Diverter WA	400212	1		
38		Spring	400217	1		
39		Deflector - Side	400417	1		
40		Nut Wing 1/4 - 20	*8166007	1		

\* Notes standard hardware that may be purchased locally.

Specify model and serial number when ordering replacement parts.

# MAINTENANCE



Use only a qualified mechanic for any adjustments, disassembly or any kind of repair .



**WARNING: TO AVOID PERSONAL INJURY, ALWAYS TURN MACHINE OFF, MAKE SURE ALL MOVING PARTS COME TO A COMPLETE STOP.**



**DISCONNECT SPARK PLUG WIRE BEFORE SERVICING UNIT.**



ENGINE: See engine manufacturer operator's instructions.



**RECONNECT SPARK PLUG WIRE AND GUARDS BEFORE STARTING ENGINE.**

17.1

**Maintenance Schedule** Follow these hourly maintenance intervals.

Maintenance Operation	Every Use	Every 5 hrs. or (Daily)	Every 25 hrs.
Engine (See Engine Manual)			
Check for excessive vibration	●		
Inspect for loose parts		●	
Inspect for worn or damaged parts		●	
Lubricate wheels			●

17.2

## IMPELLER REMOVAL

1. Wait for engine to cool and disconnect spark plug.
  2. Remove grill assembly (item 9), by removing five (5) screws (item 12), around outside of grill.
  3. Remove impeller bolt and lock washer.
- NOTE: DO NOT PULL OR PRY ON IMPELLER BLADES.**
4. Pull on center hub backplate area only of impeller. If impeller slides off freely, proceed to (step 7).
  5. Place two crowbars between center hub backplate area of impeller and housing on opposite sides. Carefully pry impeller away from engine until it loosens. *Using a penetrating oil can help loosen a stuck impeller.*
  6. If the impeller does not loosen, obtain a 1" (25.4mm) longer bolt of the same diameter and thread type as the impeller bolt. Thread longer bolt by hand into the crankshaft until bolt bottoms. Using a suitable gear or wheel puller against the bolt head and the impeller back-plate (near the blades), remove impeller from shaft.
  7. Reinstall new impeller in reverse order of removal.
  8. Tighten impeller bolt. Torque impeller bolt (see parts list on page 7 for proper impeller bolt torque specifications).

**TIRE AIR PRESSURE:** Check at regular intervals and maintain.

Rear Tires only - 30 Psi. (21 kPa).

20

## TROUBLESHOOTING

Before Requesting Service Review These Suggestions

Problem	Possible Cause	Solution
Poor air performance	Air intake or exhaust clogged.	Clear clog.
Abnormal vibration.	Loose or out of balance impeller or loose engine.	Check impeller and replace if required. Check Engine.
Engine will not start.	Throttle in off position. Engine not in full choke position. Out of gasoline. Bad or old gasoline. Spark Plug wire disconnected. Dirty air cleaner.	Check throttle, choke position and gasoline. Connect spark plug wire. Clean or replace air cleaner. Or contact a qualified service person.
Engine is locked, will not pull over.	Engine problem.	Contact an engine servicing dealer for engine problems.

22.1

### Engine Service and Warranty

Contact your nearest engine manufacturer's authorized servicing dealer.

21

### Serial Plate

Record your machine model, serial number and date-of-purchase and where purchased

1803 S. Jefferson  
P.O. Box 308  
Lee's Summit,  
MO 64063 / USA  
Tel (816) 524-9666  
Fax (816) 524-6983

Model	Serial No.
Unit(Weight)	Engine Power
<input type="text"/> lbs. <input type="text"/> kg	<input type="text"/> kW <input type="text"/> rpm

Operator \_\_\_\_\_

22

### WARRANTY PROCEDURE

Please fill in the WARRANTY CARD and send the upper part to Billy Goat. The WARRANTY terms are stated on the lower part which remains with the user. Whenever a Billy Goat Machine is faulty due to a defect in material and / or workmanship, the owner should make a warranty claim as follows:

The Machine should be taken to the dealer from whom it was purchased or to an authorized Billy Goat dealer.

The owner should present the remaining half of the Warranty Registration Card, or, if this is not available, the invoice or receipt.

The Warranty Claim will be filled in by the authorized Billy Goat Dealer, who will send it with the faulty part to Billy Goat headquarters.

The Quality / Service department at Billy Goat headquarters will study the claim and parts and will notify their conclusions.

The decision by the Quality / Service department at Billy Goat headquarters to approve or reject a Warranty claim is final and binding.

*Note:* To process a Warranty Claim, it is necessary to quote the Model & Serial number who are printed on the Billy Goat Serial-Plate.



BILLY GOAT INDUSTRIES INC.  
P.O. BOX 308 (1803 S JEFFERSON LEE'S SUMMIT, MO 64063 / USA  
PHONE: 816-524-9666 FAX: 816-524-6983

[Gardening Supply](#)

<a href="#"><u>Patio Barbecues</u></a>	<a href="#"><u>Outdoor Barbecues</u></a>	<a href="#"><u>Landmann Barbecues</u></a>	<a href="#"><u>Gas Barbecues UK</u></a>
<a href="#"><u>Charcoal Barbecues</u></a>	<a href="#"><u>Gas Barbecues</u></a>	<a href="#"><u>Cheap Gas Barbecues</u></a>	<a href="#"><u>Masonry Barbecues</u></a>
<a href="#"><u>Brush Cutters</u></a>	<a href="#"><u>Brushcutters</u></a>	<a href="#"><u>Blower Vacs</u></a>	<a href="#"><u>Chain Saws</u></a>
<a href="#"><u>Chainsaws</u></a>	<a href="#"><u>Cultivators</u></a>	<a href="#"><u>Cylinder Lawn Mowers</u></a>	<a href="#"><u>Echo Chainsaws</u></a>
<a href="#"><u>Echo Strimmers</u></a>	<a href="#"><u>Electric Chainsaws</u></a>	<a href="#"><u>Fertiliser Spreaders</u></a>	<a href="#"><u>Garden Blowers</u></a>
<a href="#"><u>Garden Rollers</u></a>	<a href="#"><u>Lawn Rollers</u></a>	<a href="#"><u>Garden Shredders</u></a>	<a href="#"><u>Garden Tractors</u></a>
<a href="#"><u>Garden Vacuums</u></a>	<a href="#"><u>Hayter Lawn Mowers</u></a>	<a href="#"><u>Hedge Cutters</u></a>	<a href="#"><u>Hedgecutters</u></a>
<a href="#"><u>Hover Mowers</u></a>	<a href="#"><u>Husqvarna chainsaws</u></a>	<a href="#"><u>Kawasaki Brush Cutters</u></a>	<a href="#"><u>Kawasaki</u></a>
<a href="#"><u>Lawn Mowers</u></a>	<a href="#"><u>Scarifiers</u></a>	<a href="#"><u>Lawn Tractors</u></a>	<a href="#"><u>Strimmers</u></a>
<a href="#"><u>Leaf Vacuums</u></a>	<a href="#"><u>Petrol Chainsaws</u></a>	<a href="#"><u>Petrol Hedge Cutters</u></a>	<a href="#"><u>Leaf Blowers</u></a>
<a href="#"><u>Ride on mowers</u></a>	<a href="#"><u>Rotary Mowers</u></a>	<a href="#"><u>Rotavators</u></a>	<a href="#"><u>Ride on lawn</u></a>
<a href="#"><u>Electric Garden</u></a>	<a href="#"><u>Petrol Garden</u></a>	<a href="#"><u>ALKO Garden Shredders</u></a>	<a href="#"><u>mowers</u></a>
<a href="#"><u>Shredders</u></a>	<a href="#"><u>shredders</u></a>	<a href="#"><u>Gas Patio Heaters</u></a>	<a href="#"><u>Ryobi Strimmers</u></a>
<a href="#"><u>Garden Patio Heaters</u></a>	<a href="#"><u>Outdoor Patio Heaters</u></a>	<a href="#"><u>Greenhouse Heaters</u></a>	<a href="#"><u>Cheap Garden</u></a>
<a href="#"><u>Patio Heater Covers</u></a>	<a href="#"><u>Garden Heaters</u></a>	<a href="#"><u>Table Top Patio Heaters</u></a>	<a href="#"><u>Shredders</u></a>
<a href="#"><u>Gas Greenhouse</u></a>	<a href="#"><u>Stainless Steel Patio</u></a>	<a href="#"><u>Kawasaki brushcutters</u></a>	<a href="#"><u>Patio Heaters</u></a>
<a href="#"><u>heaters</u></a>	<a href="#"><u>Heaters</u></a>	<a href="#"><u>Midgeater Plus</u></a>	<a href="#"><u>Green house</u></a>
<a href="#"><u>Grit Spreaders</u></a>	<a href="#"><u>Gardena Hedgecutters</u></a>		<a href="#"><u>heaters</u></a>
<a href="#"><u>Patio Heaters with</u></a>	<a href="#"><u>Christmas Gardening</u></a>		<a href="#"><u>Patio Heaters UK</u></a>
<a href="#"><u>Covers</u></a>	<a href="#"><u>Gifts</u></a>		<a href="#"><u>Petrol Strimmers</u></a>
<a href="#"><u>Cylinder Mowers</u></a>			<a href="#"><u>Barbecues</u></a>